

Adjustable Range Reflective
MR3 Series

Thank you very much for purchasing Panasonic products. Read this Instruction Manual carefully and thoroughly for the correct and optimum use of this product. Kindly keep this manual in a convenient place for quick reference.

WARNING

- Never use this product as a sensing device for personnel protection.
- In case of using sensing devices for personnel protection, use products which meet laws and standards, such as OSHA, ANSI or IEC etc., for personnel protection applicable in each region or country.

1 DIMENSIONS (Unit: mm)

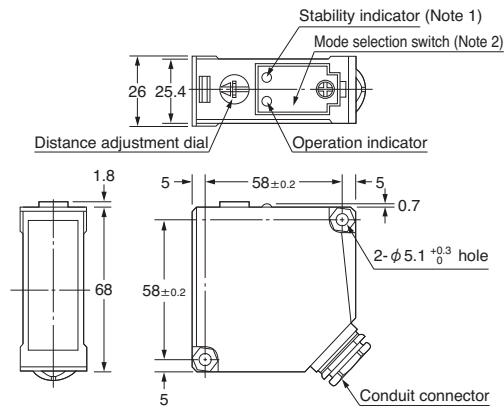

Notes: 1) It is the beam-receiving indicator for the MR3-T.
2) MR3-T incorporates a mode selection switch and timer adjustment dial.

2 WIRING DIAGRAMS

- Amplifier selfcontained -AC / DC type
- Amplifier selfcontained -DC type

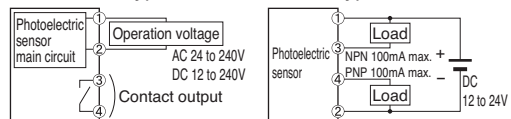

3 CAUTIONS IN USE

- This product has been developed / produced for industrial use only.
- Usable over the ambient temperature range of -25 to +55°C.
- If an external surge voltage exceeding 4kV (Amplifier self-contained-AC / DC type), 500V (Amplifier self-contained-DC type) [(±1.2×50) μsec single polarity full wave voltage] is impressed, the internal circuit will be damaged, and a surge suppressing element should be used.
- When the attached brackets are used, the tightening torque of the screws should be 0.78N·m or less. If the brackets are not used, this sensor should be installed on a smooth surface.
- Mounting screws of the terminal cover and display cover should certainly be tightened to maintain the water-resistance, however, the tightening torque of the screws should be of 0.29 to 0.49N·m.
- Be sure that the mounting direction of the sensor is acceptable to the movement direction of an object.

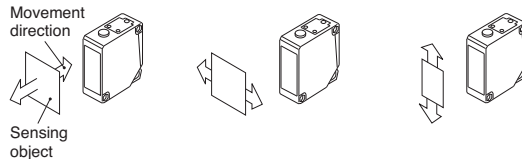

- When the sensor detects specular targets such as aluminum and copper foil or target with a coated glossy surface, a little change in angle or wrinkles on the surface of targets may make the detection impossible.
- When there is a specular or a glossy object behind the target, a little angular change of background object may cause an erroneous operation. When it happens, re-install the sensor tilted to verify the detection once again.

4 DISTANCE ADJUSTMENT

- 1 Point the sensing surface of photoelectric sensor in the direction of detection and fasten.
- 2 Set the distance adjustment dial to its maximum setting (FAR). Slowly turn it counterclockwise without a sensing object present and note the position where the operation indicator LED [beam-receiving LED] turns off. The maximum position at which the LED turns off is the FAR position.
- 3 Place a sensing object in the sensing position and set the distance adjustment dial to its minimum setting (NEAR). Slowly turn it clockwise and note the position where the operation indicator LED [beam-receiving LED] turns on. The minimum position at which the LED turns on is the NEAR position.
- 4 Set the distance adjustment dial to the middle of the two positions found in 2 and 3 above.
- 5 Mount securely so that the photoelectric sensor is not shifted from alignment by vibrations or impact.

* [] shows for MR3-T.

5 WIRING CONNECTIONS

- To maintain a water-resistance performance, the cord should have an outer diameter between φ9 and φ11mm with a smooth covering material that allows the conduit connector to be securely tightened. However, the tightening torque for the mounting screw should be 1.47 to 1.96N·m.
- If pressure terminals are to be used, fix the connected pressure terminals to a terminal (M3.5 screw). The dimensions of suitable pressure terminals are as below.

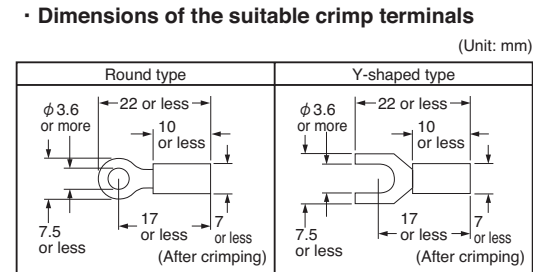

- The cables should be treated as below.

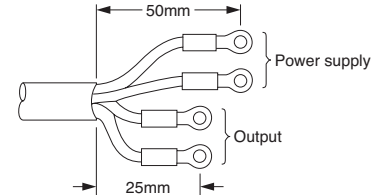

- The tightening torque of the terminal screws should be 0.49N·m or less.
- When a market-available switching regulator is used, ground the F.G. (frame ground) terminal and the G. (ground) terminal. If they are not grounded, malfunction may be caused by switching noise.
- When extending the cable, use a cable of 0.3mm² or more and limit its length within 100m.

6 TIMER OPERATION

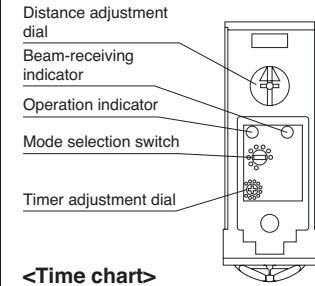

<Time chart>

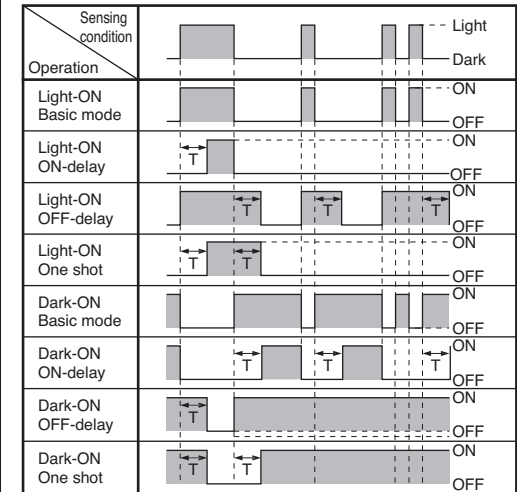

Timer period: T = 0.1 to 5sec. (variable)

7 INTENDED PRODUCTS FOR CE MARKING

- The models listed under 'Catalogue' come with CE Marking.
- As for all other models, please contact our office.



Panasonic Electric Works SUNX Co., Ltd.

http://panasonic-electric-works.net/sunx
Overseas Sales Division (Head Office)
 2431-1 Ushiyama-cho, Kasugai-shi, Aichi, 486-0901, Japan
 Phone: +81-568-33-7861 FAX: +81-568-33-8591
Europe Headquarter: Panasonic Electric Works Europe AG
 Rudolf-Diesel-Ring 2, D-83607 Holzkirchen, Germany
 Phone: +49-8024-648-0
US Headquarter: Panasonic Electric Works Corporation of America
 629 Central Avenue New Providence, New Jersey 07974 USA
 Phone: +1-908-464-3550